

DIN-Rail Mount Power Supply with a Wide Power Range of 3 to 240 W

- Universal voltage range: 100 to 240 VAC
- UL 508 listed on all models
- Class 2 approved on all models below 240-W, except dual-output types
- Undervoltage indicators on all. 90-W, 100-W and 240-W T-Models have indicator and output
- Meets EN61000-3-2 (limits for harmonic current emissions) with PFC on 240-W models
- Parallel operation capability (90-W, 100-W and 240-W)
- Finger-safe terminal block with cover according to VDE0106/P100
- Approvals: UL, CSA, VDE, and CE
- 3-year warranty



Ordering Information

■ SWITCHING POWER SUPPLIES

Rated input voltage	Power ratings	Output voltage	Output current	Functional configuration	Part number		
100 to 240 VAC	3 W	5 V	0.6 A	Single output	S82K-00305		
		12 V	0.25 A		S82K-00312		
		15 V	0.2 A		S82K-00315		
		24 V	0.13 A		S82K-00324		
	7.5 W	5 V	1.5 A		Single output	S82K-00705	
		12 V	0.6 A			S82K-00712	
		15 V	0.5 A			S82K-00715	
		24 V	0.3 A			S82K-00724	
		+12 V/-12 V	0.3 A/0.2 A			Dual output	S82K-00727
		+15 V/-15 V	0.2 A/0.2 A				S82K-00728
	15 W	5 V	2.5 A		Single output	S82K-01505	
		12 V	1.2 A			S82K-01512	
		24 V	0.6 A	S82K-01524			
	30 W	5 V	5.0 A	Single output		S82K-03005	
		12 V	2.5 A			S82K-03012	
		24 V	1.3 A			S82K-03024	
	50 W	24 V	2.1 A	Single output		S82K-05024	

(This table continues on the next page.)

Ordering Information Table – continued from previous page

Rated input voltage	Power ratings	Output voltage	Output current	Functional configuration	Part number
120/240 VAC selectable	90 W	24 V	3.75 A	Single output	S82K-09024
	100 W	24 V	4.2 A		S82K-10024
	240 W	24 V	10 A		S82K-24024
	240 W	24 V	10 A	With undervoltage alarm indicator/output	S82K-24024T
100 to 240 VAC	240 W	24 V	10 A	With PFC	S82K-P24024

■ MODEL NUMBER LEGEND

3- to 100-W Models

S82K -
 1 2

1. Power Ratings

003: 3 W
 007: 7.5 W
 015: 15 W
 030: 30 W
 050: 50 W
 090: 90 W
 100: 100 W

2. Output Voltage

05: 5 VDC
 12: 12 VDC
 15: 15 VDC
 24: 24 VDC
 27: Dual output +12/-12 VDC
 28: Dual output +15/-15 VDC

240-W Models

S82K - 24024
 1 2

1. Power Factor Correction

None: No
 P: Yes

2. Undervoltage alarm indicator/output

None: No
 T: Yes

■ ACCESSORIES (SOLD SEPARATELY)

DIN Rail

Item	Length	Width	Part number
DIN-rail (See <i>Dimensions</i> section for details.)	0.5 m (1.64 ft)	7.3 mm (0.29 in)	PFP-50N
	1 m (3.28 ft)	7.3 mm (0.29 in)	PFP-100N
	1 m (3.28 ft)	16 mm (0.63 in)	PFP-100N2

Noise Filter

Item	Applicable power supply	Part number
Noise filter	For 3- to 50-W models	S82Y-JF3-N
	For 90-W and 100-W models	S82Y-JF6-N

Specifications

■ RATINGS/CHARACTERISTICS

Item			Non-PFC models								PFC model
			Single output		Dual outputs	Single output					
			3 W	7.5 W	7.5 W	15 W	30 W	50 W	90 W	100 W	240 W
Efficiency (typical)			60% to 80% (Varies depending on specifications.)								
Input	Voltage (see note 1)	AC	100 to 240 V (85 to 264 V)					100 V (85 to 132 V)/ 200 V (170 to 264 V) Selectable		100 V (85 to 132 V)/ 200 V (170 to 253 V) Selectable	100 to 230 V (85 V to 253 V)
		DC	90 to 350 V (see note 2)				Not possible				
Frequency		50/60 Hz (47 to 450 Hz)								50/60 Hz (47 to 63 Hz)	
Current (see note 3)	100-V input	0.15 A max.	0.25 A max.		0.45 A max.	0.9 A max.	1.3 A max.	2.5 A max.		5.5 A max.	4 A max.
	200-V input				0.25 A max.	0.6 A max.	0.8 A max.	1.5 A max.		3.5 A max.	2 A max.
Power factor		---								0.95 min.	
Leakage current (see note 3)	100-V input	0.5 mA max.									
	200-V input	1 mA max.									
Inrush current (see note 3)	100-V input	15 A max.				25 A max.					
	200-V input	30 A max.				50 A max.					
Noise filter		Yes									

Note: 1. Use with DC voltage input is beyond the conditions of approval or conformance to applicable safety standards.

2. Use the 7.5-W single-output models under the load of 90% max. if the voltage range is between 90 and 110 VDC.

3. Defined with a 100 % load and the rated input voltage (100 or 200 VAC).

Specifications Table – continued from previous page

Item		Non-PFC models									PFC model
		Single output		Dual outputs	Single output						
		3 W	7.5 W	7.5 W	15 W	30 W	50 W	90 W	100 W	240 W	
Output (see note 2)	Voltage adjustment range	±10% (V.ADJ)		Not possible (see note 3)	±10% (V.ADJ); -10% to 15% for S82K-03012/-03024/-05024						
Output (see note 2)	Ripple (see note 1)	2% (p-p) max.									
	Input variation influence	0.5 % max. (at 85 to 264 VAC input, 100% load)					0.5 % max. (at 85 to 132 VAC/170 to 264 VAC input, 100% load)	0.5 % max. (at 85 to 132 VAC/170 to 253 VAC input, 100% load)	0.5 % max. (at 85 to 253 VAC input, 100 % load)		
	Load variation influence	1.5% max. (0 to 100% load)	+V: 1.5% max. -V: 3 % max. (0 to 100% load)	1.5% max. (0 to 100% load)			1.5% max. (10 to 100% load)				
	Temperature variation influence (see note 1)	0.05%/°C max.									
	Rise time	100 ms max. (up to 90% of output voltage at rated input and output)					200 ms max.	300 ms max.	1,000 ms max.		
	Hold time (see note 1)	20 ms min.									

(This table continues on the next page.)

- Note: 1. Defined with a 100% load and the rated input voltage (100 or 200 VAC).
 2. The output specification is defined at the power supply output terminals.
 3. The settings for the output voltage must be within the following range:
 +V: ±1% of the rated value
 -V: ±5% of the rated value
 4. When using the 7.5-W single-output models within the input voltage range between 90 and 110 VDC, the protection function will operate at a current of 95% to 160% of the rated load current.
 5. When the ambient temperature exceeds 25°C, the overload protection function will operate at a current of 92% to 111% of the rated load current.
 6. Circuit-breaker type. To reset, turn the input power supply OFF, then after 1 min has elapsed, turn the input power supply ON again.

Specifications Table – continued from previous page

Item		Non-PFC models									PFC model
		Single output		Dual outputs	Single output						
		3 W	7.5 W	7.5 W	15 W	30 W	50 W	90 W	100 W	240 W	240 W
Additional function	Overload protection	105% to 160% of rated load current, automatic reset (see note 4)		105% to 250% of rated load current, automatic reset	105% to 160% of rated load current, automatic reset			101% to 111% of rated load current, automatic reset (see note 5)	105% to 160% of rated load current, automatic reset		
	Overvoltage protection (see note 6)	No							S82K-24024T model only	No	
	Undervoltage alarm indicator (DC LOW indicator)	Yes (color: red)							S82K-24024T model only	No	
	Undervoltage alarm output (DC LOW output)	No					Yes		S82K-24024T model only	No	
	Parallel operation	Impossible						Possible (2 units max.)			

(This table continues on the next page.)

- Note: 1. Defined with a 100% load and the rated input voltage (100 or 200 VAC).
 2. The output specification is defined at the power supply output terminals.
 3. The settings for the output voltage must be within the following range:
 +V: $\pm 1\%$ of the rated value
 -V: $\pm 5\%$ of the rated value
 4. When using the 7.5-W single-output models within the input voltage range between 90 and 110 VDC, the protection function will operate at a current of 95% to 160% of the rated load current.
 5. When the ambient temperature exceeds 25°C, the overload protection function will operate at a current of 92% to 111% of the rated load current.
 6. Circuit-breaker type. To reset, turn the input power supply OFF, then after 1 min has elapsed, turn the input power supply ON again.

■ REFERENCE VALUE

Item	Value	Definition
Reliability (MTBF)	135,000 hrs min.	MTBF stands for Mean Time Between Failures, which is calculated according to the probability of accidental device failures, and indicates reliability of devices. Therefore, it does not necessarily represent a life of the product.
Life expectancy	8 yrs. min.	The life expectancy indicates average operating hours under the ambient temperature of 40°C and a load rate of 50%. Normally this is determined by the life expectancy of the built-in aluminum electrolytic capacitor.

Engineering Data

■ DERATING CURVE

3-/7.5-/15-/30-/50-/90-W/
100-W Models

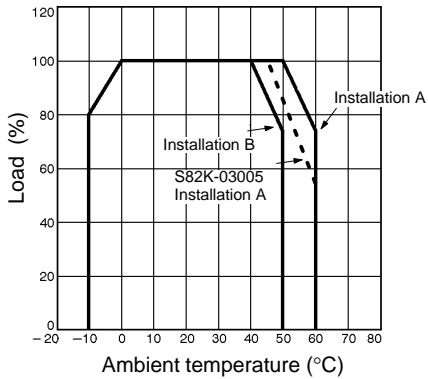

Note: When using the 7.5-W single-output models within the input voltage range between 90 and 110 VDC, the load rate will become 90% or less.
When using the 90-W model at an ambient temperature exceeding 25°C, the load rate will become 90% or less.

240-W Model

Single-Unit Operation

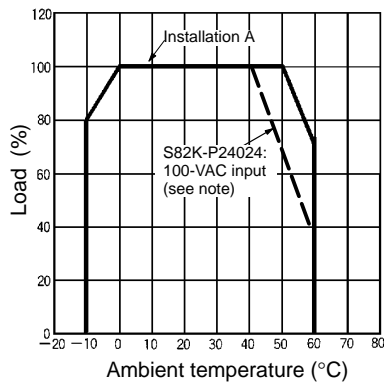

Note: 100-V input: 85 to 132 VAC

Parallel-Unit Operation

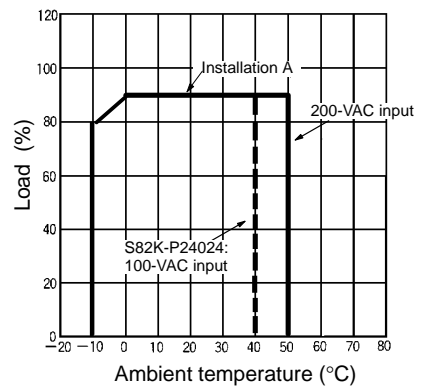

Mounting Position

The derating curve can be ensured for these two kinds of installations.

(A) Standard (Vertical) Installation

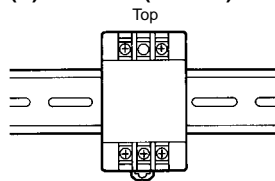

(B) Horizontal Installation

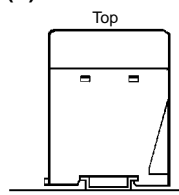

Note: Not permitted for 240-W models.

OVERLOAD PROTECTION

The Power Supply has an overload protection function that protects the load and the power supply from possible damage by overcurrent. When the output current rises above a set value (105% of the rated output current of most models; 101% of the rated output current for 90-W model), the protection function is triggered, decreasing the output voltage. When the output current falls within the rated range, the overload protection function is automatically cleared.

When using the 7.5-W single-output models within the input voltage range between 90 and 110 VDC, the protection function will operate at a current of 95% of the rated load current.

When using the 90-W model at an ambient temperature exceeding 25°C, the protection function will operate at a current of 92% of the rated load current.

Note: To avoid damage to the unit or deterioration of the internal circuitry, do not short-circuit the output terminals of the S82K or use the S82K with excessive output current for a long time.

3-/7.5-/15-/90-W/100-/240-W Models

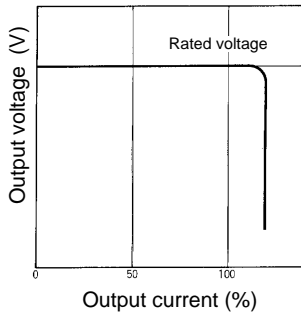

30-/50-W Models

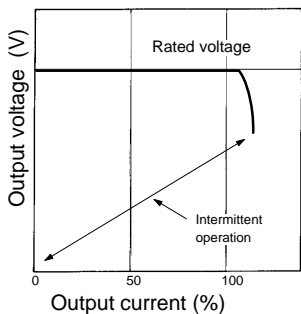

When Using ± Output Models

The +V output detects the total output power (+V output and -V output) to trigger the short-circuit protection against overcurrent. This protection varies depending on the -V output state. The -V output independently triggers the short-circuit protection.

OVERVOLTAGE PROTECTION (S82K-24024T MODELS ONLY)

The Power Supply is provided with an overvoltage protection function that protects the load and the Power Supply from possible damage by overvoltage. When the output voltage rises above a set value, the protection function is triggered, shutting off the output voltage. If this occurs, reset the Power Supply by turning it off for 1 minute min. and then turning it on again.

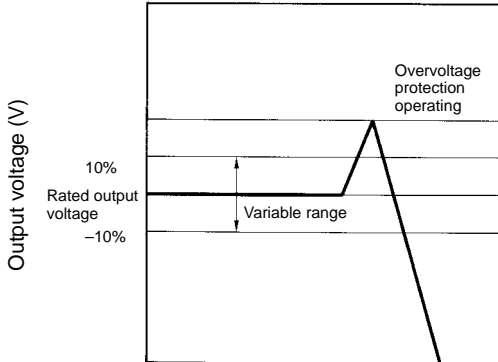

■ INRUSH CURRENT, RISE TIME, HOLD TIME

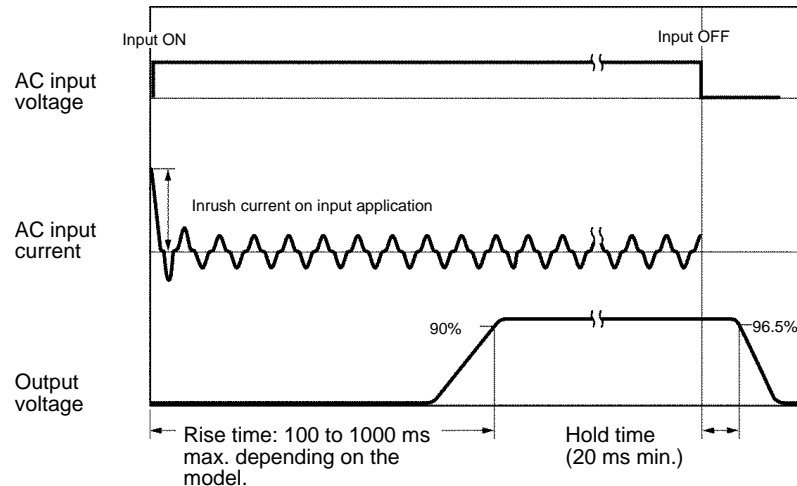

Operation

■ UNDERVOLTAGE ALARM INDICATOR AND OUTPUT FUNCTION (ALL MODELS EXCEPT S82K-24024/P24024)

If the output voltage at the output terminal drops to 75% to 90% of the rated voltage, the red indicator of the S82K (DC LOW indicator) will be lit. In the case of the S82K-10024/24024T, a voltage drop alarm will be output via the relay available in the models (DC LOW output).

This function detects the voltage at the output terminal of the Power Supply. To check the precise output voltage, measure the voltage at the terminal of the load.

Indicator	Voltage	Operation of 09024/10024/24024T's output (DC LOW output) (see note 2)
Green: DC ON Red: DC LOW	If the voltage at the output terminal is more than 90% of the rated voltage, the green indicator will be lit.	
Green: DC ON Red: DC LOW (see note 1)	If the voltage at the output terminal is 75% to 90%, the red indicator will be lit.	
Green: DC ON Red: DC LOW	If the voltage at the output terminal is 0 V, both the green and red indicators will not be lit.	

- Note: 1. The more the voltage at the output terminal drops, the darker both the green and red indicators will be.
2. The relay contacts have a capacity of 0.1 A at 24 VDC.

■ BLOCK DIAGRAMS

S82K-003□□ (3 W)

S82K-007□□ (7.5 W, Single Output)

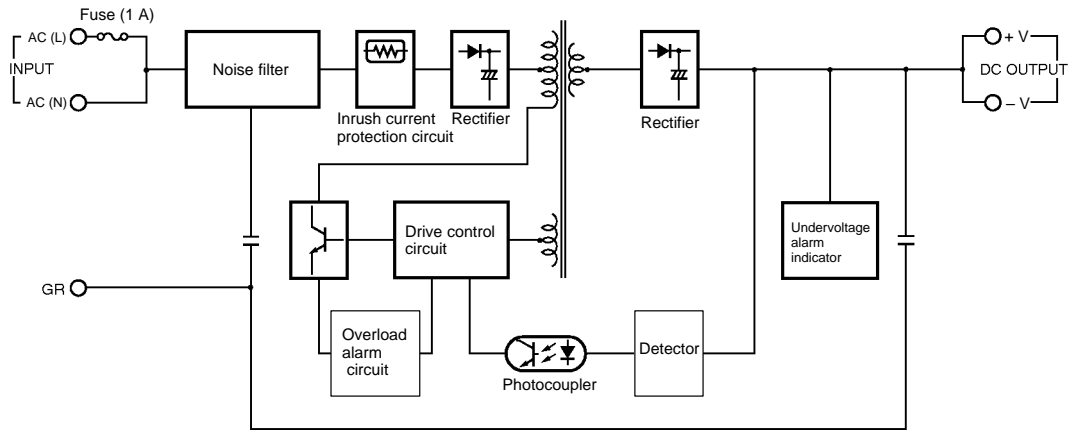

S82K-007□□ (7.5 W, Dual Outputs)

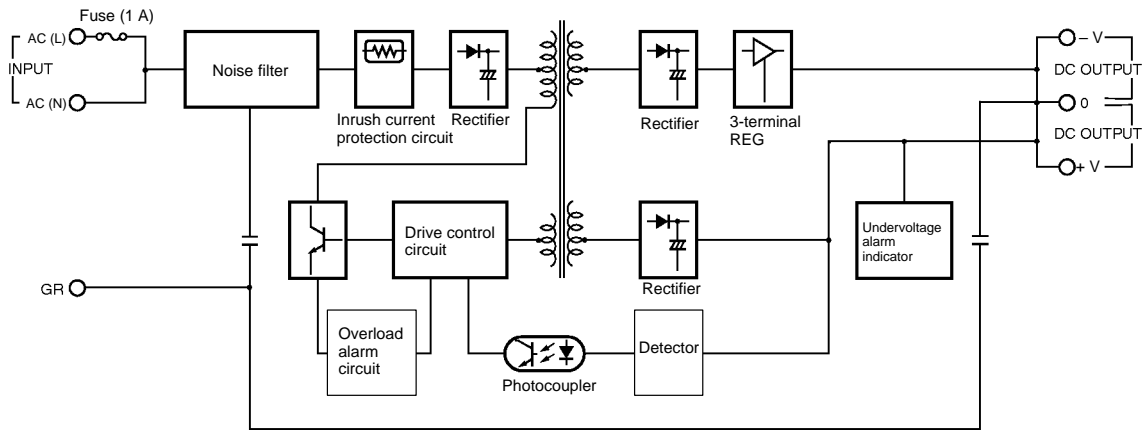

S82K-015□□ (15 W)

S82K-030□□ (30 W)

S82K-05024 (50 W)

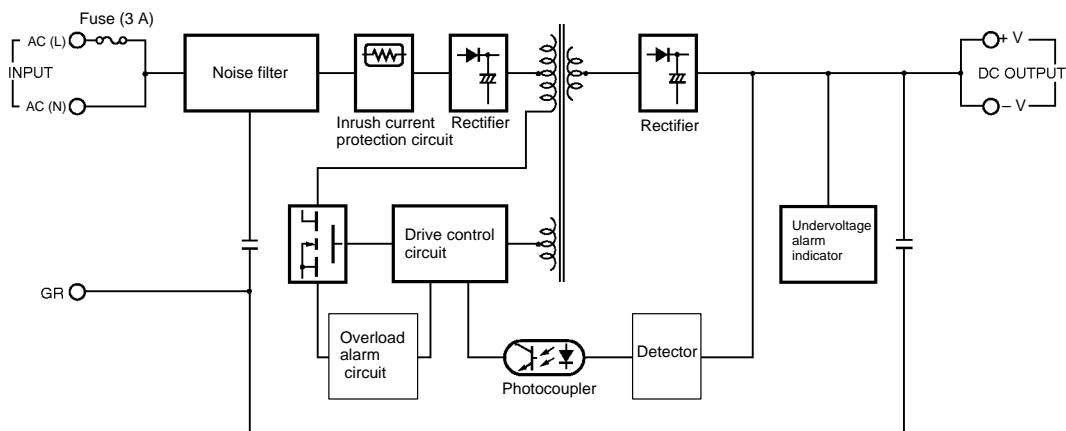

S82K-09024 (90 W)
S82K-10024 (100 W)

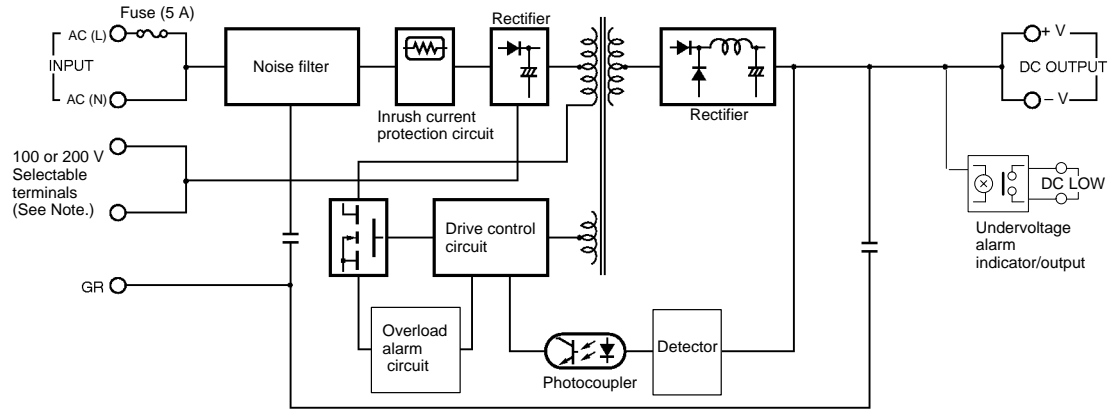

Note: Use the short bar to short-circuit terminals 7 and 8 to select 100 to 120 VAC and remove the short bar to select 200 to 240 VAC.

S82K-24024 (240 W)

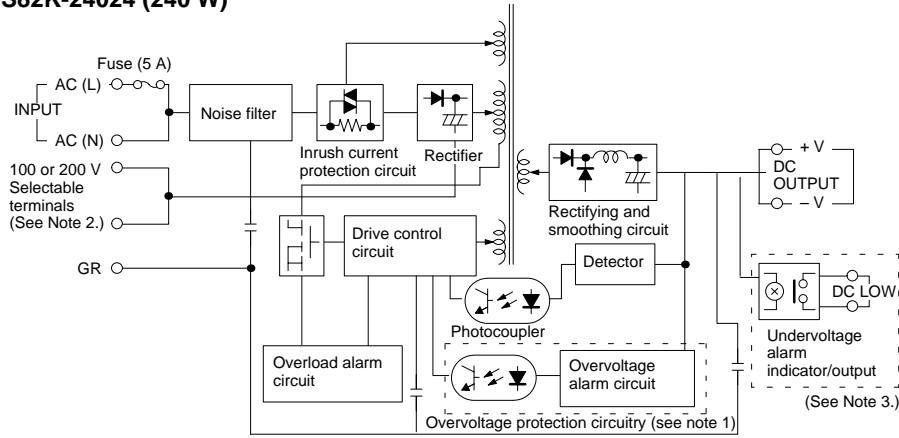

- Note: 1. The overvoltage protection circuitry is available in the S82K-24024T only.
 2. Use the short bar to short-circuit terminals 7 and 8 to select 100 to 120 VAC and remove the short bar to select 200 to 230 VAC.
 3. The undervoltage alarm indicator is available in the S82K-24024T.

S82K-P24024 (240 W)

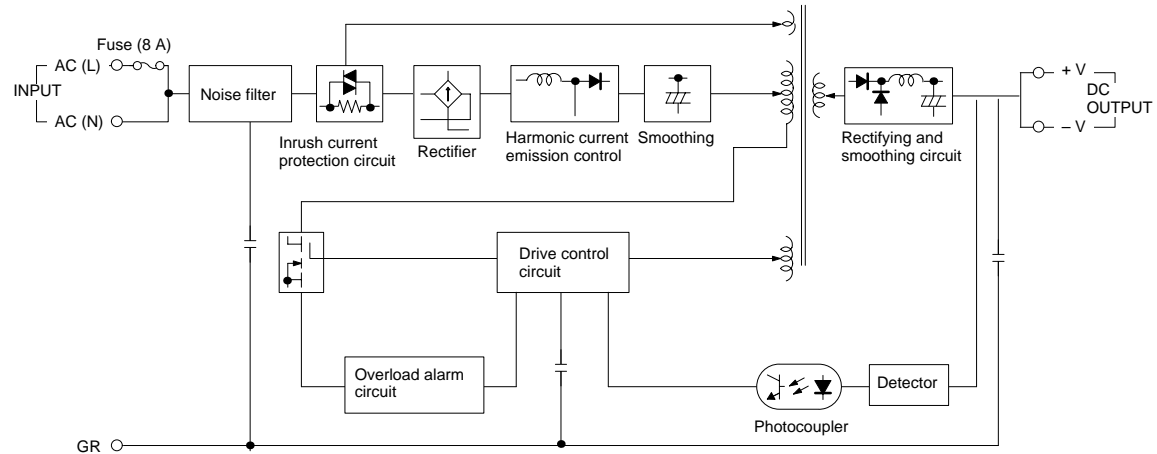

Dimensions

Unit: mm (inch)

- S82K-003□□ (3 W)
- S82K-007□□ (7.5 W)

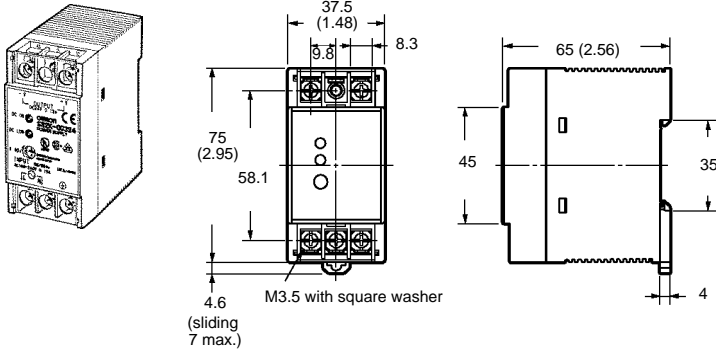

Mounting Brackets (Supplied with the Power Supply)

Used when not mounting the Power Supply directly on the DIN rail.

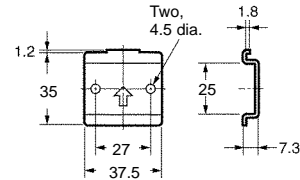

Mounting Holes

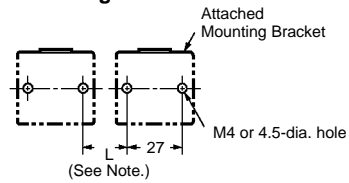

Note: If more than one Power Supply is installed in a row, keep a distance of 20 mm min. (L = 20 mm min.) between each adjacent Power Supply.

- S82K-015□□ (15 W)

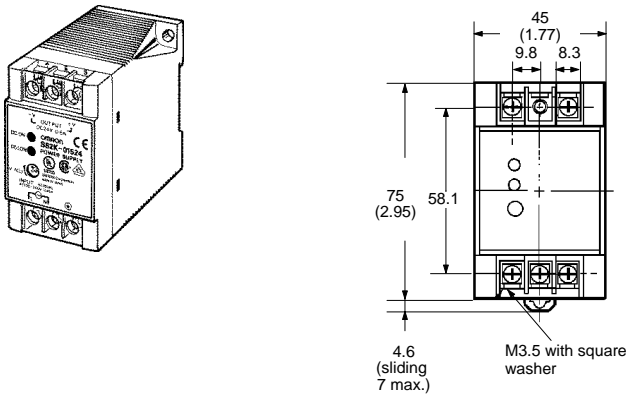

Mounting Holes

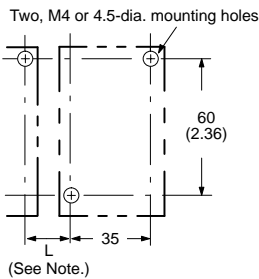

Note: If more than one Power Supply is installed in a row, keep a distance of 20 mm min. (L = 20 mm min.) between each adjacent Power Supply.

Unit: mm (inch)

■ S82K-030□□ (30 W)
S82K-05024 (50 W)

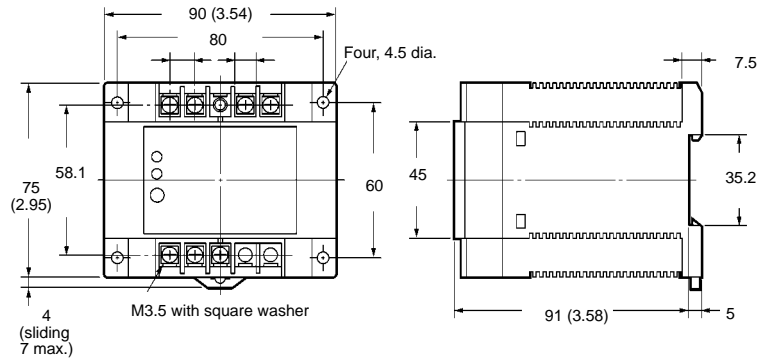
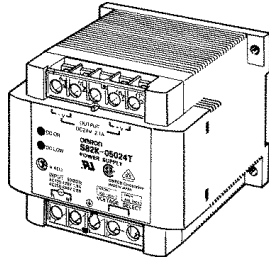

Mounting Holes

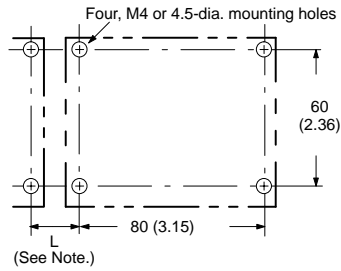

Note: If more than one Power Supply is installed in a row, keep a distance of 20 mm min. (L = 20 mm min.) between each adjacent Power Supply.

■ S82K-09024 (90 W)
S82K-10024 (100 W)

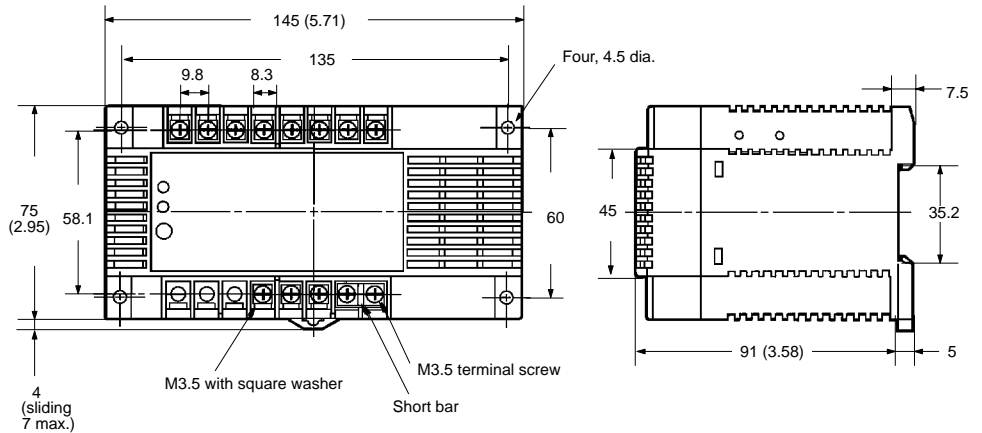
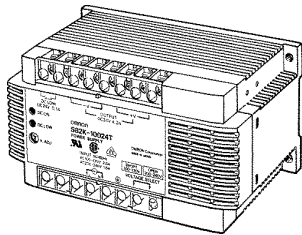

Mounting Holes

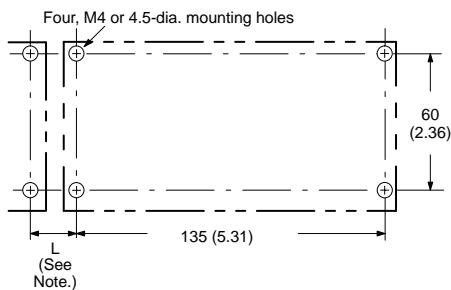

Note: If more than one Power Supply is installed in a row, keep a distance of 20 mm min. (L = 20 mm min.) between each adjacent Power Supply.