

CMCP240 Proximity Probe Speed Sensor

Features:

- Short Barrel
- 3-Wire Hookup
- Meets IP670
- Thick nickel-plated brass barrel
- Wrench flats for easy installation
- Solid potted internal circuitry
- Withstands shocks and water
- High visibility indicator



Specifications:

Supply Voltage	12 to 24 VDC
Sensor Body Style	Metal Cylindrical
Barrel Size	M12
Target Material	Ferrous
Sensing Distance	1.5 mm
Contact Type	No
Amplifier Type	Self-contained
Output Type	NPN or PNP
Connection	Pre-wired
Shielded / Unshielded	Shielded
Response Frequency	1.5 kHz

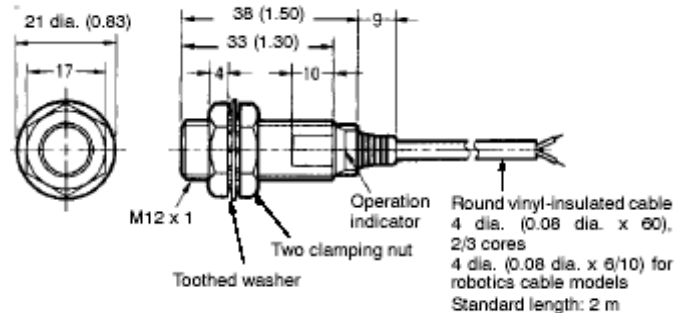

Ordering Information:

CMCP240	-00	NPN Proximity Speed Sensor
	-01	NPN Proximity Speed Sensor With Mounting Bracket
CMCP240P	-00	PNP Proximity Speed Sensor
	-01	PNP Proximity Speed Sensor With Mounting Bracket