

OPERATION MANUAL

**CMCP535A DISPLACEMENT MONITOR
CMCP535 DISPLACEMENT TRANSMITTER**

REV. A 10-12-98

Model Description:

The **CMCP535** is a 4-20mA Displacement Transmitter. It is factory configured for compatibility with a low-impedance velocity transducer, or electro-mechanical velocity transducer. The input signal is processed to determine the overall vibration amplitude in terms of peak-to-peak displacement. The output is a standard 4-20mA current proportional to the this amplitude, within a specified full scale range such as 0 - 10 mils peak-to-peak (p-p). This output is suitable for direct connection to a Programmable Logic Controller (PLC) or Distributed Control System (DCS). A BNC connector on the front of the unit provides buffered access to the transducer signal for connection to portable instruments.

This unit can be also ordered as a stand alone Monitor by adding suffix "**A**" to the basic model number: **CMCP535A**. When ordered in this configuration, the unit is supplied with an alarm module that includes independent set point alarms for ALERT and DANGER levels. Each set point has a corresponding adjustment potentiometer and LED indicator on the front panel, and an output relay that can be jumper configured for either latching or non-latching operation. The alarm LED will turn "ON" and the corresponding relay will actuate whenever overall vibration levels exceed the corresponding set point for more than a jumper selectable delay time. The alarm module provides a front panel accessible BNC connector and associated selector switch for reading the current vibration level (CV) or alarm set points (A or D) with a standard digital volt-meter. The alarm module also provides a transducer "OK" relay, and a trip-multiply function that allows the alarm levels to be temporarily increased by a factor of two during machine start-up. Both monitors and transmitters mount on standard DIN rail.

Power:

The CMCP535(A) requires externally supplied DC power. The chosen power supply should have a nominal output of +24Vdc and be capable of supplying a minimum of 55mA for each CMCP535 in the system, or 110 mA for each CMCP535A in the system. A linear-regulated power-supply dedicated to the vibration monitoring system is recommended. It is also recommended that connections between the power-supply and the monitors be made with twisted-shielded instrument cable. The cable shield should float at the monitor/transmitter, and connect to common at the power-supply/system common end only. The CMCP535(A) regulates dc power internally to prevent a fault on the output of one channel from affecting other channels. When power is first applied to a monitor or transmitter after connecting the transducer, there will be a delay of approximately 30 seconds before the "OK" LED turns "ON".

Transducer:

The CMCP535(A) is factory configured for use with one of two transducer types. The specific type is identified by a dash number immediately following the basic P.N. on the side label. This number is the transducer sensitivity in either mV/g or mV/in/sec., followed by an "V" for a low-impedance velocity transducers (mV/in/second) or "EV" for electro-mechanical, self-generating velocity transducers (mV/in/sec). Example: "-100V" indicates the transducer is a 100mV/in/sec low-impedance velocity transducer (type 1 below). Other sensitivities than indicated here are available.

Type 1. Low-impedance constant-current powered velocity sensor (typically 100 mV/in/sec.)

Type 2. Self-generating electro-mechanical velocity transducer. (typically 500 mV/in/sec)

Transducer Cable:

The CMCP535(A) provides power for the transducer via a nominal 4.4 mA constant current source. This is generally enough current to allow operation with transducer cables extending up to about 100 ft. However, It is strongly recommended that the monitor / transmitter be mounted as close as practical to the associated transducer. This will prevent signal distortion associated with current drive limitations, and will minimize interference from external electro-magnetic noise sources (EMI). A well shielded, properly installed transducer cable is absolutely necessary to obtain reliable operation. Twisted-shielded pair cables designed and pre-fitted with the proper transducer connector, and sold for this specific purpose are highly recommended. The cable shield should be open at the transducer end, and connected to common (xdcr "-" terminal) at the monitor/transmitter input only. The cable should be routed as far away from other electrical circuits as possible, and run in metal conduit where possible.

Transducer OK Circuit:

The CMCP535(A) incorporates a transducer "OK" circuit. This feature continuously monitors the transducer bias and signal voltage. If this voltage exceeds pre-set limits, the 4-20 mA output current is reduced to less than 2 mA (typically 0 mA) to allow detection of the fault condition at the associated PLC or DCS system. A green "OK" LED on the front of the unit (normally "ON" in an "OK" condition) turns "OFF" to provide a local indication of the fault condition. For low impedance, constant current powered transducers, this circuit will effectively detect open, shorted, or reversed transducer connections. If a fault is detected that subsequently is repaired or goes away, there will be a delay of approximately 30 seconds before the unit returns to the "OK" condition and the "OK" LED turns back "ON". On the CMCP530A, a detected fault will also disable the "ALERT" and "DANGER" alarms/relays until the fault is removed and an "OK" condition exists. NOTE: When configured for use with an electro-mechanical transducer ("EV"), the "OK" circuit will *only* detect an open circuit condition of the transducer/cable.

Full Scale Range:

The CMCP535(A) comes factory set calibrated to the full-scale range specified at the time of order. Other ranges may be implemented (see table below) by installing jumpers on internal headers as shown in the table below. See "Opening the case" to gain access to these jumpers. Changing ranges by jumper selection only, will introduce an error of .5% typical, 2% max. For greater accuracy the system SPAN must be re-calibrated. (See the drawing: CMCP535 JUMPER LOCATIONS, at the back of this manual)

Option:	Range:	Jumper
-01	5 Mils p-p	E2
-02	10 Mils p-p	E3
-03	15 Mils p-p	E2 and E3
-04	20 Mils p-p	E3 and E4
-05	25 Mils p-p	E2 and E3 and E4

The factory calibrated range is listed on the side label as a dash number. If a range other than shown above is indicated, the unit has been modified for a special range or set of ranges.

4-20 mA Output:

The primary output of the monitor/transmitter is the 4-20 mA current output which is scaled proportional to the full scale range of the unit. IE: If the range is 0 - 10 mils p-p, then 4 mA indicates a reading of 0.00 mils, and 20 mA indicates a reading of 10.0 mils. This output is intended to drive a maximum resistive load of 600 Ohms with respect to system common at the PLC/DCS input. A precision ½ watt, 250 Ohm resistor is the recommended load. This will convert the 4-20 mA current reading into a 1-5 Vdc reading for the PLC/DCS. A short to ground (common) on this output *will not* damage it.

Buffered Output:

The CMCP535(A) provides buffered access to the transducer signal via a BNC connector on the front of the unit. This output has the same sensitivity, units, and bias voltage as the transducer itself. This output can be connected to portable analysis instruments, or can be used to check the bias-output-voltage (BOV) of low-impedance transducers using a digital volt-meter. The Buffered output is un-filtered. The buffered output signal is also available on a screw terminal at the top of the unit. **NOTE: For electro-mechanical velocity transducers only:** The buffered output sensitivity is scaled to 100 mV/in/sec, regardless of the actual input sensitivity. IE: a 145 mV/in/sec transducer will have a scaled buffered output sensitivity of 100 mV/in/sec.

ALARM MODULE:

Alert and Danger Alarm Set-Point Adjustment:

The Alert and Danger alarm set-points can be independently set in the field by turning the front panel selector switch to the associated position (A or D) and adjusting the associated front-panel potentiometer until the correct DC voltage is measured at the BNC connector located directly above the selector switch. Adjusting the set-point requires the use of a digital volt-meter, knowledge of the full scale range of the monitor, and the desired set-point as a percentage of the full scale range. The voltage measured at the BNC will vary between 0 Vdc and 5 Vdc, corresponding to 0 to Full-scale. IE: 2.5 Vdc represents 50% of full scale, 3.75 Vdc represents 75% of full scale. To calculate the required set point voltage, use the equation, $5(.xx)$ where $.xx$ is the desired percentage expressed as a decimal fraction of the full scale range. IE. $5(.60) = 3.00$ Vdc for a set-point of 60% of the full scale range. Turning the potentiometer clockwise increases the set point voltage.

Alert and Danger Alarm Delay Adjustment:

The Alert and Danger alarm delays can be independently set by internal jumper selection to .1, 1, 3, 6, or 10 seconds. The purpose of the delay is to reduce nuisance alarms caused by external electrical noise and/or transient vibration events. Both the Alert and Danger delay are factory set to the 3 second position.. To change the delay, open the unit and move the delay jumpers to the proper position (See: CMCP500 SERIES ALARM MODULE JUMPER LOCATIONS, at the back of this manual).

Latching/Non-Latching Alarms:

The Alert and Danger alarms are factory set for NON-LATCHING operation. This means that whenever the vibration level drops below the associated set-point for more than about 1 second, the associated relay will de-energize and the alarm LED will turn off. The alarms can also be set for LATCHING operation by installing shunts on jumpers E1 and E2 respectively on the Alarm module circuit board (See: CMCP500 SERIES ALARM MODULE JUMPER LOCATIONS, at the back of this manual). Latched alarms may be reset by closing the RESET (RST) and COMMON (COM) contacts at the top of the unit. This may be done with an external switch, dry contact relay, or by shorting the terminals together by hand. **DO NOT APPLY VOLTAGE TO EITHER THE "RST" or "COM" TERMINALS.** If several monitors are mounted together, the "RST" terminals may be daisy-chained together and switched to "COM" (system common) as a group.

Trip Multiply:

The alarm module provides a trip multiply feature. This feature allows the user to temporarily double (standard) or triple (jumper selectable) the normal set points during periods of normal high vibration such as start-ups. To actuate the trip multiply feature, the Tx terminal at the top of the alarm module must be closed to the adjacent "COM" terminal. This may be done with an external switch, dry contact relay, or by shorting the terminals together by hand. **DO NOT APPLY VOLTAGE TO EITHER THE "Tx" or "COM" TERMINALS.** If several monitors are mounted together, the "Tx" terminals may be daisy-chained together and switched to "COM" (system common) as a group.

Alarm Relays:

The Alert Danger and OK relays are independent, single-pole-double throw relays. NO, ARM, and NC contacts are available via plugable screw-connector at the bottom of the monitor. Ok relay contacts are available on fixed screw terminals at the bottom front of the alarm module (See drawing: CMCP500 Series Relays And External Connections). Relay contacts are rated 5 Amps at 30 Vdc or 125 Vac, resistive load. This rating includes any inrush current that the load draws. For loads that are not purely resistive the contact switching capability will need to be considered carefully in terms of this inrush current. The entire subject of relay application is too large to address here, so the user is cautioned to use care in the application of the relays. The factory intended purpose of providing relay contacts is to operate relatively low power alarm annunciators, act as a dry or low dc voltage contact closure input to other systems, or act to actuate an appropriately sized slave relay for larger loads such as shutting down a motor. Relays are socketed and can be replaced.

Test/Calibration Instruments:

The test equipment listed below is required to perform Zero and span calibrations:

- (1) +24 Vdc linear regulated power supply
- (1) Variable DC power supply with floating output (for simulating BOV).
- (1) 4.5 digit DC/True RMS reading digital volt/current meter. Fluke 87 or better
- (1) Sine wave AC signal generator with floating output.

Zero Calibration:

Zero output has been factory calibrated and should not need further adjustment under normal use. However, should adjustment become necessary, complete the following steps.

1. Connect the test instruments listed above as shown on the Test/Calibration drawing.
2. With the signal generator **OFF**, measure the output current from the mA terminal, using digital current-meter.
3. Wait until the output has completely settled to a stable value, and then adjust potentiometer R24 (farthest from the circuit board edge) until the output is 4000 uA +/- 5 uA.

Full-Scale (SPAN) Calibration:

The full-scale output has been factory calibrated. It should only need to be checked/adjusted once every two years under normal use. However, should adjustment become necessary (such as with a range change) complete the following steps.

1. Connect the test instruments listed above as shown on the Test/Calibration drawing.
2. Calculate the proper full-scale test input voltage from the following options:

Low-Impedance Velocity transducers: Test signal is 100.00 Hz sine-Wave, with +10Vdc offset.

100mV/in/sec: Test input in V_{rms} is: (Full-Scale range in mils pp) x .022214

500mV/in/sec: Test input in V_{rms} is: (Full-Scale range in mils pp) x .111072

Electro-mechanical velocity transducers: Test signal is 100.00 Hz, sine-wave, with no dc offset.

100mV/in/sec: Test input in V_{rms} is: (Full-Scale range in mils pp) x .022214

145mV/in/sec: Test input in V_{rms} is: (Full-Scale range in mils pp) x .032211

500mV/in/sec: Test input in V_{rms} is: (Full-Scale range in mils pp) x .111072

3. Turn on the signal generator, set the correct frequency and amplitude for the appropriate full scale RMS voltage as measured with a True-RMS digital volt-meter **directly at the + transducer input terminal**. Measure the output current using the digital current-meter. Wait until the output has settled to a stable value, and then adjust potentiometer R23 (closest to the circuit board edge) until the output is 20.00 mA +/- .02 mA. Turning the potentiometer clockwise increases the output.

Opening The Case:

Opening the case is best done with a small flat-blade screwdriver. On transmitters (1" wide units) insert the tip of the screwdriver between the right-side cover (as viewed from the front of the unit) and the DIN rail mounting foot at the back of the unit and gently leverage the blade to begin separating the cover from the rest of the unit. Carefully work your way around to the front of the unit to complete removal of the cover, exposing the circuit board components. On Monitors (1.6" wide units), you must first CAREFULLY separate the two halves of the unit at the center. The sides do not need to be removed. This is done by working the screwdriver around the middle of the unit in the same general manner described above. As the two halves start to become separated, you will see that they are still attached by a short ribbon cable inside. This cable can be carefully removed by pulling it away from the left hand side of the unit. The cable stays with the right hand side permanently. **CAUTION:** When re-installing this cable, make sure it is properly connected to the mating connector, and that the bend in the cable goes towards the front panel side of the unit. **IF THE UNIT IS CLOSED WITH THE BEND TOWARDS THE BACK, THE RIBBON CABLE CAN BE DAMAGED.** Also, make sure the ribbon cables' connector does not catch on the relays when pressing the unit back together.

Filter Selection and Installation:

1. Filters for use with the CMCP500 series transmitters and monitors are modular and may be factory or field installed. Filter modules have a 4-pole butterworth response which attenuates frequencies beyond the specified corner frequency by approximately -24dB/octave. The Corner frequency as defined by standard convention is the frequency at which the filter attenuates the signal by -3dB, or approximately 30%. For Low-Pass filters, signals frequencies less than 60% of the specified corner frequency are attenuated less than 1%, and for frequencies less than 75% of the corner, attenuation due to the filter is less than 5%. For High-Pass filters the numbers translate to 1.66 times the corner, and 1.33 times the corner for 1% and 5% attenuations respectively. Filters modules can be ordered with corner frequencies from as low as 5 Hz (120RPM) to 2000 Hz (120,000 RPM) or more. High-Pass and Low-Pass filters can be cascaded to form a Band-Pass response but care must be taken to assure that the specified corner frequencies are far enough apart to minimize attenuation due to corner interaction in the Pass-Band. Usually a factor of 5 or more between corners will work.
2. When installing filters, you will be working in direct contact with sensitive electronic components. To assure your safety and to avoid damaging the unit you must first disconnect and remove the unit from its installation. You must also make sure you do not accidentally cause a static discharge to any part of the unit. This is best accomplished by wearing an anti-static ground strap around your wrist while working on the unit. At a minimum, touch a grounded metal object to discharge yourself prior to handling the open unit.

3. To install filter modules you must first open the monitor/transmitter. See "Opening The Case" above..
4. With the cover removed you will notice two 16-pin sockets near the rear of the printed circuit board. These are where you will install the filter modules. You should also locate jumpers E1 and E5 which are next to the sockets. (CAUTION: TO AVOID DAMAGING THE UNIT, DO NOT TOUCH ANY CIRCUIT BOARD COMPONENTS OTHER THAN THOSE INDICATED BELOW).
5. To install a **High-Pass** filter module, first remove jumper **E5**, then install the filter module in the socket marked **U12** (this is the socket in the corner). Use care to assure that you align pin 1 of the module (indicated on its label) with pin 1 of the socket (the pin next to the U12 marking). Note: Filters only have 5 pins.
6. To install a **Low-Pass** filter module, first remove jumper **E1**, then install the filter module in the socket marked **U9** (this is the socket closest to the center-rear of the circuit board). Use care to assure that you align pin 1 of the module (indicated on its label) with pin 1 of the socket (the pin next to the U9 marking).
7. Re-assemble the unit.

4

3

2

1

REVISIONS			
ZONE	REV	DESCRIPTION	DATE

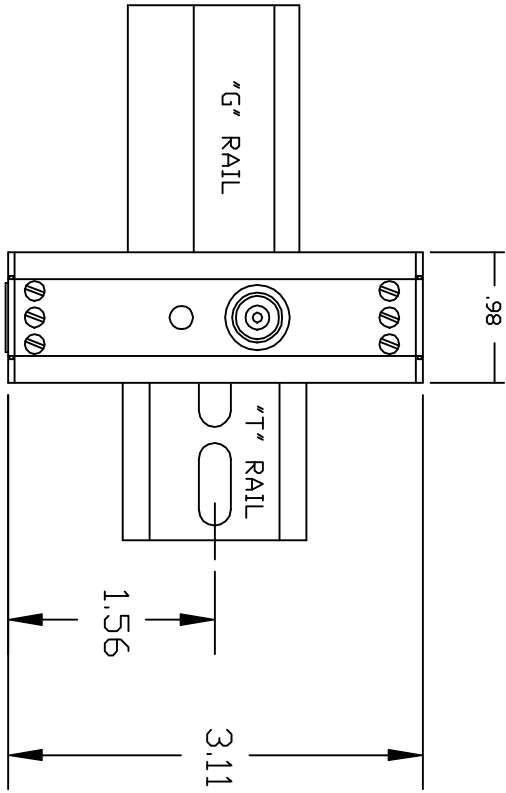
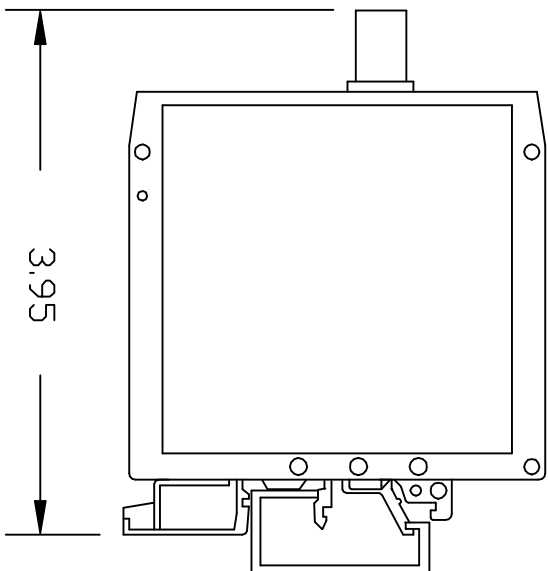

A

B

C

D

4

3

2

1

CMCP500 SERIES TRANSMITTER			
MOUNTING AND OUTLINE			
SIZE	FORM NO.	DWG. NO.	REV.
SCALE	NONE	SHEET 1 OF 1	

A

B

C

D

REVISIONS				
ZONE	REV	DESCRIPTION	DATE	APPROVED

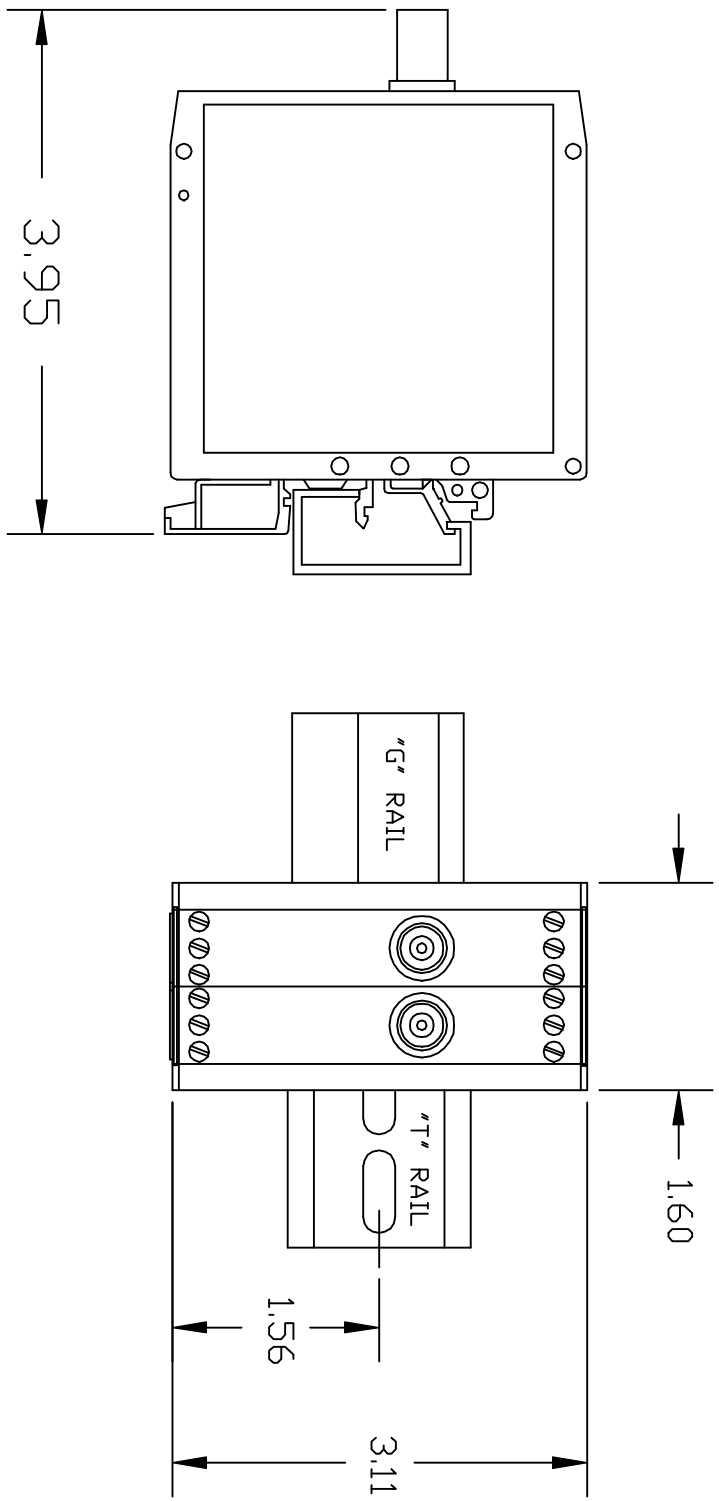

CMCP500 SERIES MONITOR MOUNTING AND OUTLINE			
SIZE	FORM NO.	DWG NO.	REV
SCALE NONE			
SHEET 1 OF 1			

4

3

2

1

REVISIONS			
ZONE	REV	DESCRIPTION	DATE

VIBRATION TRANSDUCER

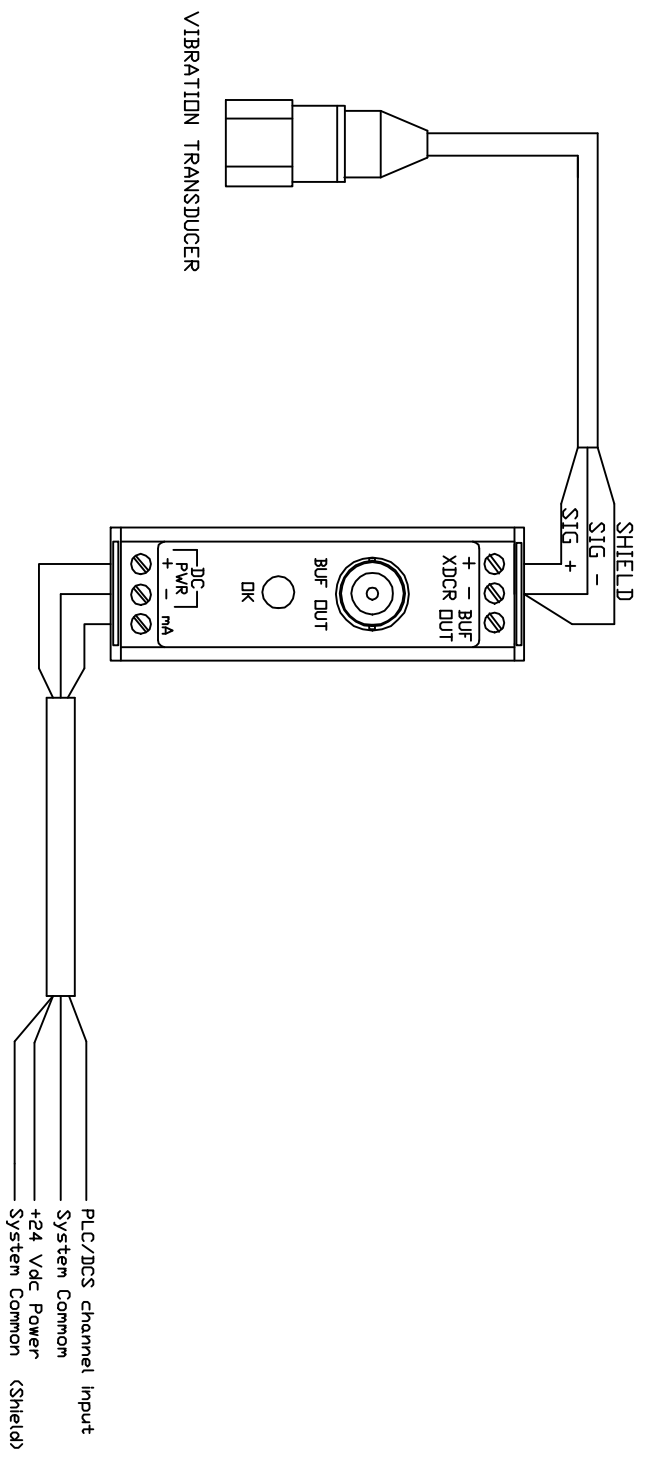

A

B

C

D

4

3

2

1

CMCP500 SERIES CONNECTIONS			
TRANSDUCER/POWER/OUTPUT			
SIZE	FORM NO.	DWG. NO.	REV.
SCALE	NONE		
SHEET 1 OF 1			

A

B

C

D

4

3

2

1

REVISIONS				
ZONE	REV	DESCRIPTION	DATE	APPROVED

TOP PLUGGABLE TERMINAL (for external meter connections)

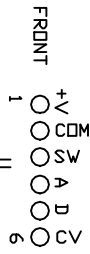

- +V - AUX. POWER OUTPUT (+20VDC at 20 mA max.)
- CDM - AUX. COMMON
- SW - SWITCHED (front panel rotary switch) OUTPUT (0-5VDC)
- A - ALERT SET-POINT (0-5VDC)
- D - DANGER SET-POINT (0-5VDC)
- CV - CURRENT VALUE (0-5VDC)

Alarm reset ('RST'), and trip multiply ('TX') terminals. External contact closure to the adjacent 'CDM' terminal, or to instrument common activates

'DANGER' LED - Turns on when Danger setpoint is exceeded

BNC connector - Read switch selected values, using digital volt meter

Rotary switch - selects output to BNC connector above

Potentiometers for adjusting 'ALERT' and 'DANGER' setpoints. (Based on 0 to 5Vdc proportional to zero to full scale range of unit)

'ALERT' LED - Turns on when Danger setpoint is exceeded

'DK RELAY' - Normally energized. Contacts shown in 'DK' condition.

4 to 20 mA output terminal

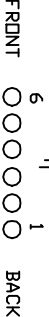

- NC - NO NC - NO
- ALERT DANGER
- ALERT & DANGER RELAYS - NORMALLY DE-ENERGIZED

CMCP500 SERIES CONNECTIONS

SIZE	PSAL NO.	DWG NO.	REV
SCALE	NONE		SHEET 1 OF 1

4

3

2

1

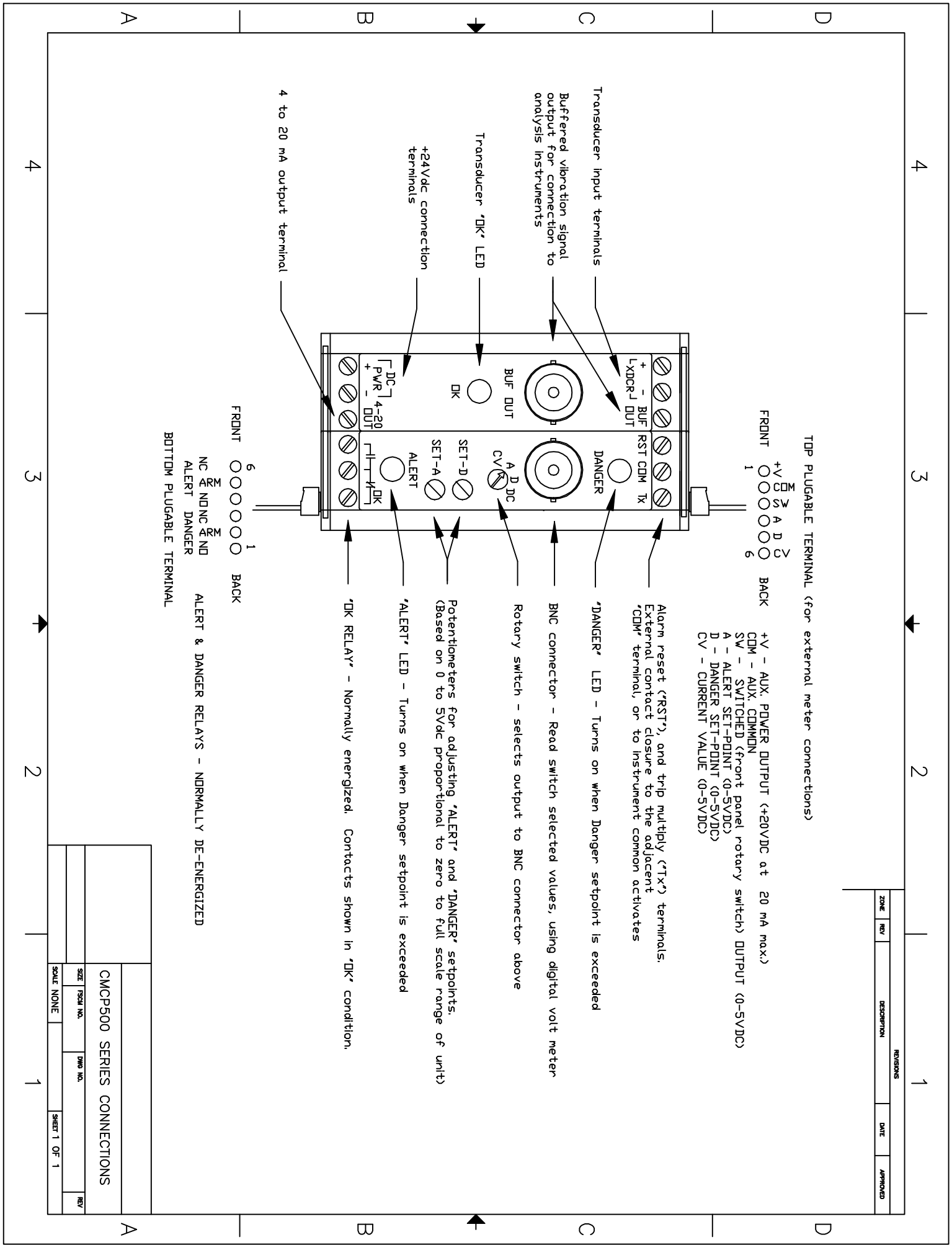

REVISIONS				
ZONE	REV	DESCRIPTION	DATE	APPROVED

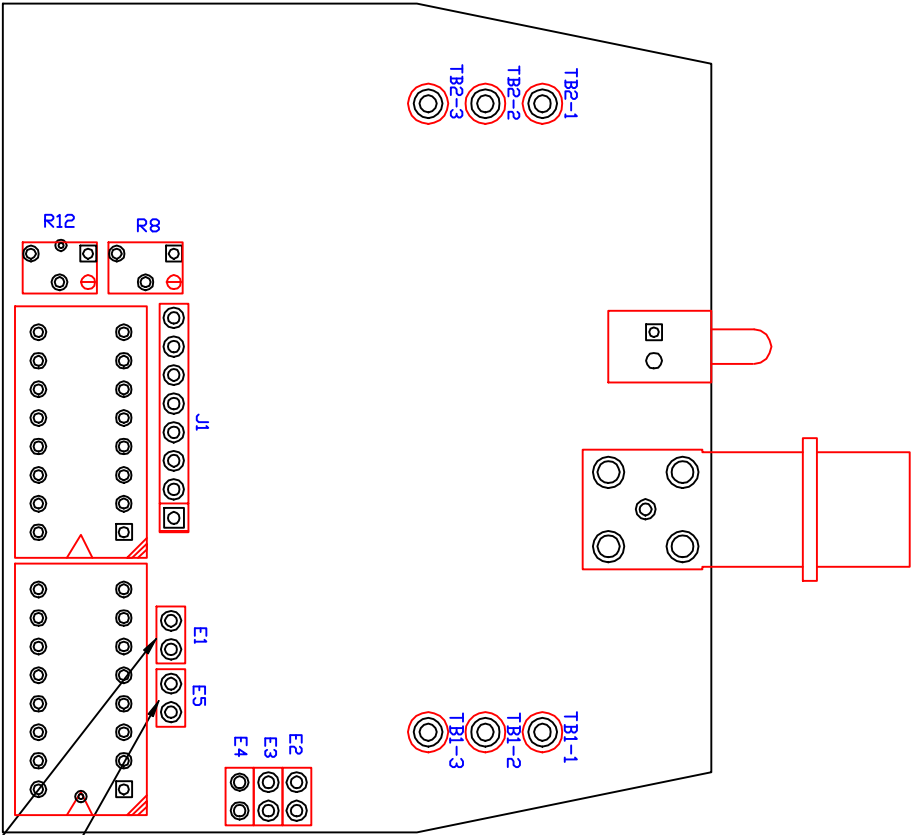

RANGE JUMPERS

- RANGE (mils p-p) INSTALL JUMPER
- 5 E2
- 10 E3
- 15 E2, E3
- 20 E3, E4
- 25 E2, E3, E4

- FILTER 1 JUMPER REMOVE TO INSTALL FILTER 1
- FILTER 2 JUMPER REMOVE TO INSTALL FILTER 2

CMCP535 JUMPER LOCATIONS			
SIZE	PSGA NO.	DWG NO.	REV
SCALE NONE			
SHEET 1 OF 1			

4

3

2

1

REVISIONS				
ZONE	REV	DESCRIPTION	DATE	APPROVED

ALERT DELAY:

E1 - .1 SEC
 E2 - 1 SEC
 E3 - 3 SEC
 E4 - 6 SEC
 E5 - 10 SEC

JUMPER INSTALLED - LATCHING
 JUMPER REMOVED - NON-LATCHING

ALERT LATCH
 DANGER LATCH
 TRIP MULTIPLY
 OPEN - 2X
 JUMP - 3X

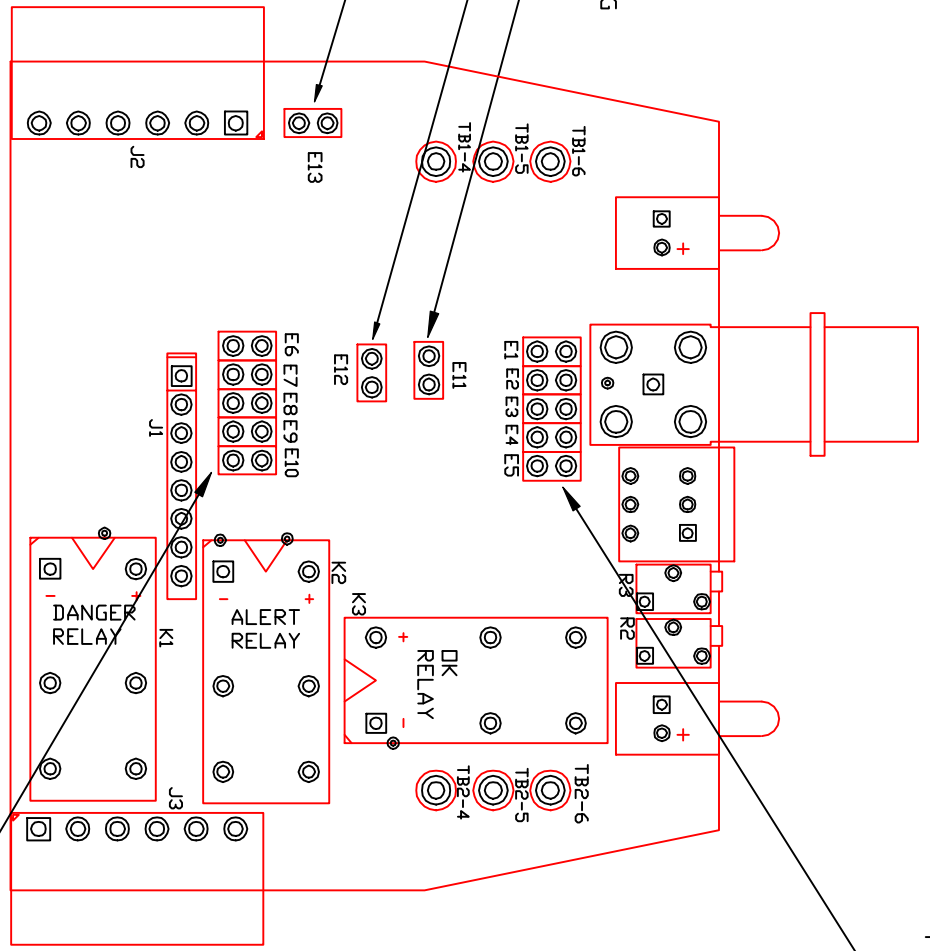

DANGER DELAY:

E6 - .1 SEC
 E7 - 1 SEC
 E8 - 3 SEC
 E9 - 6 SEC
 E10 - 10 SEC

CMCP500 SERIES ALARM MODULE
 JUMPER LOCATIONS

SIZE	FORM NO.	DWG. NO.	REV.
C			
SCALE	NONIE	SHEET 1 OF 1	

A

B

C

D

4

3

2

1

A

B

C

D

4

3

2

1

REVISIONS		
ZONE	REV	DESCRIPTION
		DATE
		APPROVED

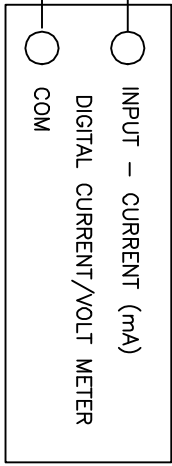
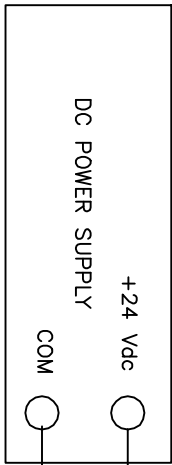
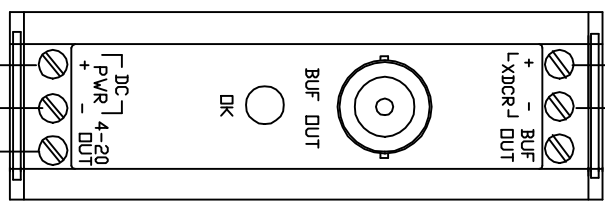
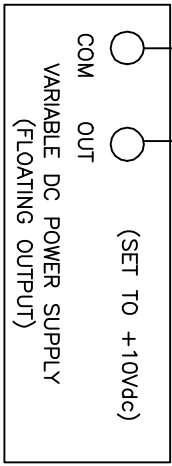
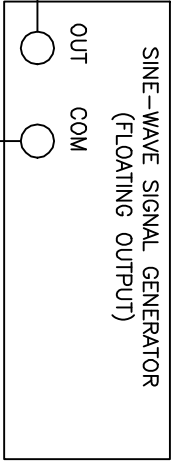
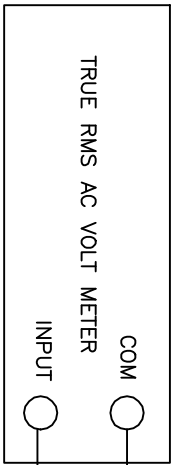

A

B

C

D

A

B

C

D

4

3

2

1

CMCP500 SERIES TEST/CALIBRATION			
SIZE	FORM NO.	DWG NO.	REV
SCALE	NONE		SHEET 1 OF 1