

OPERATION MANUAL

CMCP560 RTD TEMPERATURE TRANSMITTER CMCP560A RTD TEMPERATURE MONITOR

REV. B 8-20-00

Model Description:

The **CMCP560** is an RTD Temperature Transmitter. It can also be configured as a Temperature Monitor by adding the suffix "A" to the basic PN; **CMCP560A**. It is factory configured for use with a 3-wire, 100 Ohm, Platinum RTD. RTD resistance is processed to determine temperature in either deg., C or F as indicated on the side label, and the output is a standard 4-20 mA current proportional to the this temperature within a specified full range such as 0 - 250 deg. F. The 4-20 mA output is suitable for connection to a Programmable Logic Controller (PLC), Distributed Control System (DCS), or other readout device that accepts standard 4-20 mA inputs.

When ordered in the Monitor configuration, it also provides two independent set point alarm levels that can be used to indicate ALERT (A) and DANGER (D) conditions. Each set point has a corresponding adjustment potentiometer and LED indicator on the alarm module front panel, and an output relay that can be jumper configured for either latching or non-latching operation. The alarm LED will turn "ON" and the corresponding relay will actuate whenever temperature levels exceed the corresponding set point for more than a preset delay time (jumper selectable). The alarm module has a front panel accessible BNC connector and associated selector switch for reading the current temperature value (CV) or alarm set points (A or D) with a standard digital volt-meter. The alarm module also provides a transducer connection "OK" relay.

Power:

The CMCP560(A) requires externally supplied DC power. The DC power supply should have an nominal output of +24 Vdc and be capable of supplying a minimum of 65 mA for each CMCP560, or 120 mA for each CMCP560A in the system. A linear-regulated power-supply dedicated to the vibration monitoring system is recommended. It is also recommended that connections between the power-supply and the monitors be made with a twisted-shielded instrument cable. The cable shield should float at the monitor / transmitter installation, and connect to common at the power-supply / system-readout COMMON only. When power is first applied to a monitor or transmitter after connecting the transducer, there will be a delay of up to 30 seconds before the "OK" LED turns "ON".

Transducer:

The CMCP560A is factory configured for use with 100 Ohm, 3-wire platinum RTD's. The specific RTD Ohm value is identified by a dash number immediately following the basic P.N. on the side label. Calibration can be made for either, 385 or 392 types, and is noted on the side label

Transducer Cable:

It is strongly recommended that the transmitter be mounted as close as practical to the associated RTD. This will help to minimize interference from external noise sources (EMI). A shielded, properly installed transducer cable is recommended to obtain proper and reliable operation. The cable shield should be left open at the RTD, and connected to input terminal number 3 at the transmitter input only. Sensor cables should be routed as far away from high-energy electrical circuits as possible, and run in instrument cable trays or metal conduit where possible.

Transducer OK Circuit:

The CMCP560 incorporates a transducer "OK" circuit. This feature continuously monitors RTD wiring for shorts and open connections. If a short or open is detected, the 4-20 mA output current is reduced to less than 2 mA (typically 0 mA) to indicate the fault condition at the associated PLC or DCS system. A green "OK" LED on the front of the unit (normally "ON" in an "OK" condition) turns "OFF" to provide a local indication of the fault condition. If a fault is detected that is subsequently repaired or removed, there will be a delay of approximately 30 seconds before the unit returns to the "OK" condition and the "OK" LED turns back "ON". The "OK" circuit will not detect a short between input terminals 2 and 3.

Input Range:

The CMCP560 comes factory set calibrated to the range specified at the time of order.

Option:	Range:	Option:	Range:
-01	0-250 deg. F	-04	0-100 deg. C
-02	0-350 deg. F	-05	0-200 deg. C
-03	0-500 deg. F	-06	0-300 deg. C

The factory calibrated range is listed on the side label as a dash number. If a range other than shown above is indicated, the unit has been modified for a special range.

4-20 mA Output:

The primary output of the Monitor/Transmitter is the 4-20 mA current output which is proportional to the range of the unit. IE: If the range is 0 - 250 deg. F, then 4 mA corresponds to a reading of 0 deg. F, and 20 mA corresponds to a reading of 250 deg. F. A precision 250 Ohm resistor is the recommended load for the 4-20 mA output. This will convert the 4-20 mA current into a 1-5 Vdc reading at the PLC/DCS.

Test/Calibration:

The test equipment listed below is required to perform Zero and span adjustments:

- (1) +24 Vdc linear regulated power supply
- (1) 100 Ohm platinum RTD simulator, or precision resistors.
- (1) 4.5 digit DC/True RMS reading digital volt/current meter. Fluke 87 or better

Zero Calibration:

The Zero output has been factory calibrated for the value indicated on the side label. Small calibration adjustments can be made using the ZERO pot located on the front of the unit.

1. Connect the RTD simulator to input terminals 1 and 2 and set it for the zero-scale temp.
2. Connect a jumper from input terminal 2 to input terminal 3.
3. Adjust the ZERO potentiometer (marked Z) until the output is 4.00 mA +/- .01 mA.

Full-Scale (SPAN) Calibration:

The full-scale output has been factory calibrated for the value indicated on the side label. Small calibration adjustments can be made using the SPAN pot located on the front of the unit.

1. Connect the RTD simulator to input terminals 1 and 2, and set it for the full-scale temp.
2. Connect a jumper from input terminal 2 to input terminal 3.
3. Adjust the SPAN potentiometer (marked S) until the output is 20.00 mA +/- .01 mA.

Opening The Case:

If it becomes necessary to open the unit to make jumper changes, it is best done using a small flat-blade screwdriver. On transmitters (1" wide units) insert the tip of the screwdriver between the right-side cover (as viewed from the front of the unit) and the DIN rail mounting foot at the back of the unit and gently leverage the blade to begin separating the cover from the rest of the unit. Carefully work your way around to the front of the unit to complete removal of the cover, exposing the circuit board components. On Monitors (1.6" wide units), you must first CAREFULLY separate the two halves of the unit at the center. The sides do not need to be removed. This is done by beginning to pull the unit apart near the DIN rail mounting foot at the back of the unit. When the halves just begin to separate, work the screwdriver around towards the front of the unit in the same general manner described above. Near the front there are two steel pins that hold the unit together. These pins can be tight the first time the unit is opened, but they will come apart. As the two halves become separated, you will see that they are still attached by a short ribbon cable inside. This cable can be carefully removed by pulling it away from the left hand side of the unit. The cable stays with the right hand side (alarm side) permanently.

CAUTION: When re-installing this cable, make sure it is properly aligned and connected to the mating connector, *and* that the bend in the cable goes towards the front panel side of the unit. **IF THE UNIT IS CLOSED WITH THE BEND TOWARDS THE BACK, THE RIBBON CABLE CAN BE DAMAGED.** Also, make sure the ribbon cable connector does not catch on the edge of one of the relays when pressing the unit back together.

ALARM MODULE:

Alert and Danger Alarm Set-Point Adjustment:

The Alert and Danger alarm set-points can be independently set in the field by turning the front panel selector switch to the associated position (A or D) and adjusting the associated front-panel potentiometer until the correct DC voltage is measured at the BNC connector located directly above the selector switch. Adjusting the set-point requires the use of a digital volt-meter, knowledge of the full scale range of the monitor, and the desired set-point as a percentage of the full scale range. The voltage measured at the BNC will vary between 0 Vdc and 5 Vdc, corresponding to 0 to Full-scale. IE: 2.5 Vdc represents 50% of full scale, 3.75 Vdc represents 75% of full scale. To calculate the required set point voltage, use the equation, $5(.xx)$ where .xx is the desired percentage expressed as a decimal fraction of the full scale range. IE. $5(.60) = 3.00$ Vdc for a set-point of 60% of the full scale range. Turning the potentiometer clockwise increases the set point voltage.

Alert and Danger Alarm Delay Adjustment:

The Alert and Danger alarm delays can be independently set by internal jumper selection to .1, 1, 3, 6, or 10 seconds. The purpose of the delay is to reduce nuisance alarms caused by external electrical noise and/or transient vibration events. Both the Alert and Danger delay are factory set to the 3 second position.. To change the delay, open the unit and move the delay jumpers to the proper position (See: CMCP500 SERIES ALARM MODULE JUMPER LOCATIONS, at the back of this manual).

Latching/Non-Latching Alarms:

The Alert and Danger alarms are factory set for NON-LATCHING operation. This means that whenever the temperature level drops below the associated set-point for more than about 1 second, the associated relay will de-energize and the alarm LED will turn off. The alarms can also be set for LATCHING operation by installing jumpers on E1 and E2 respectively on the Alarm module circuit board (See: CMCP500 SERIES ALARM MODULE JUMPER LOCATIONS, at the back of this manual). Latched alarms may be reset by closing the RESET (RST) and COMMON (COM) contacts at the top of the unit. This may be done with an external switch, dry contact relay, or by shorting the terminals together by hand. **DO NOT APPLY VOLTAGE TO EITHER THE "RST" or "COM" TERMINALS.** If several monitors are mounted together, the "RST" terminals may be daisy-chained together and switched to "COM" (system common) as a group.

Trip Multiply:

The alarm module provides a trip multiply feature. This feature is provided for use with vibration monitors only, and is not intended for use with the CMCP560.

Alarm Relays:

The Alert, Danger and OK relays are independent, single-pole-double throw relays. NO, ARM, and NC contacts are available via plug-in screw-terminals at the bottom of the monitor. OK relay contacts are available on fixed screw terminals at the bottom front of the alarm module (See drawing: CMCP500 Series Relays And External Connections). Relay contacts are rated 5 Amps at 30 Vdc or 125 Vac, resistive load. This rating includes any in-rush current that the load draws. For loads that are not purely resistive the contact switching capability will need to be considered carefully relative to in-rush current. The entire subject of relay application is too broad to cover in this manual, so the user is cautioned to use care in the application of the relays. The factory intended purpose of providing relay contacts is to operate relatively low DC power alarm annunciators, act as a dry or low DC voltage contact closure input to other systems, or act to actuate an appropriately sized slave relay for larger loads. Relays are socketed and can be replaced in the field.

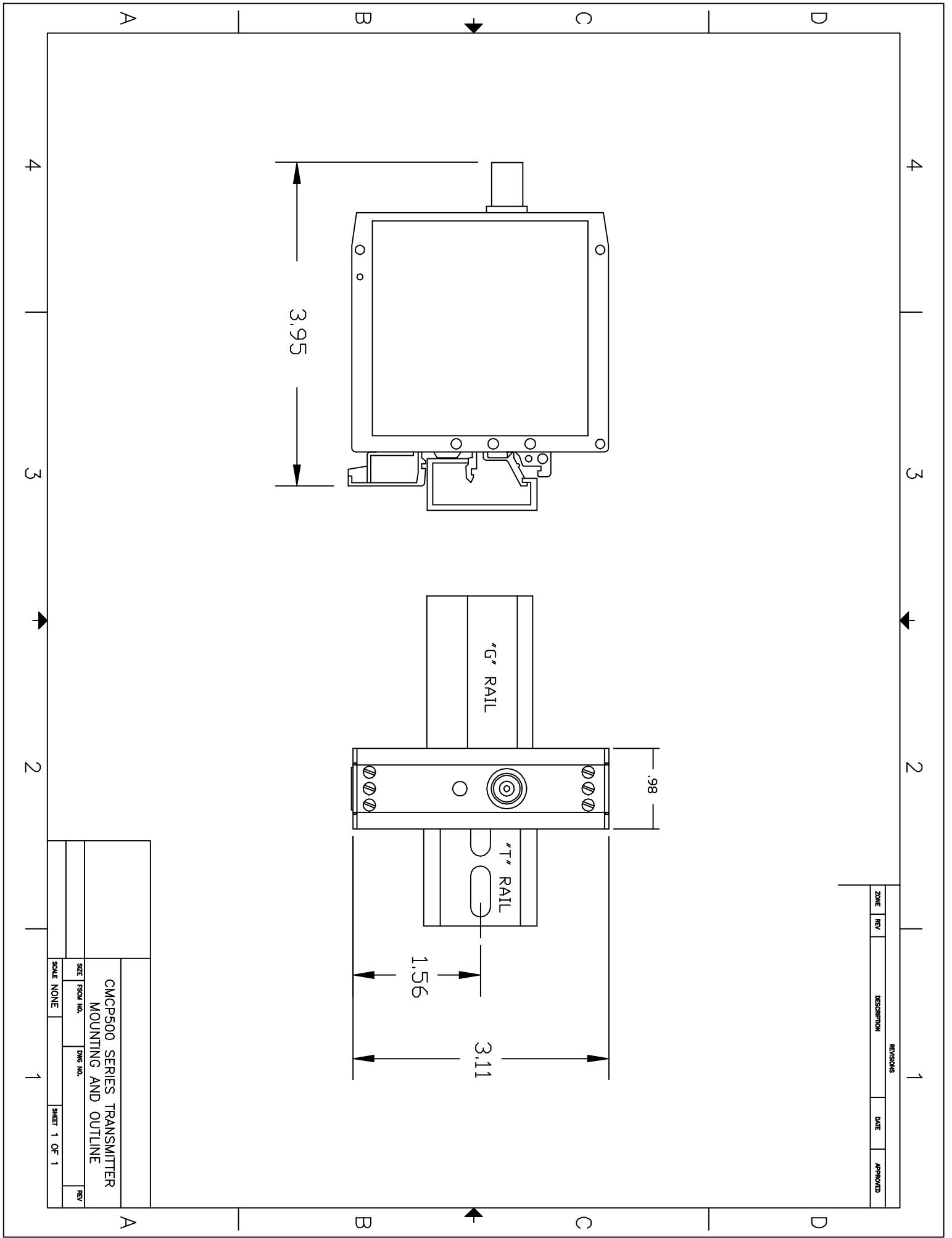

REVISIONS			
ZONE	REV	DESCRIPTION	DATE

CMCP500 SERIES TRANSMITTER		DATE	
MOUNTING AND OUTLINE		APPROVED	
SIZE	FORM NO.	DWG. NO.	REV.
SCALE	NONE	SHEET	1 OF 1

REVISIONS				
ZONE	REV	DESCRIPTION	DATE	APPROVED

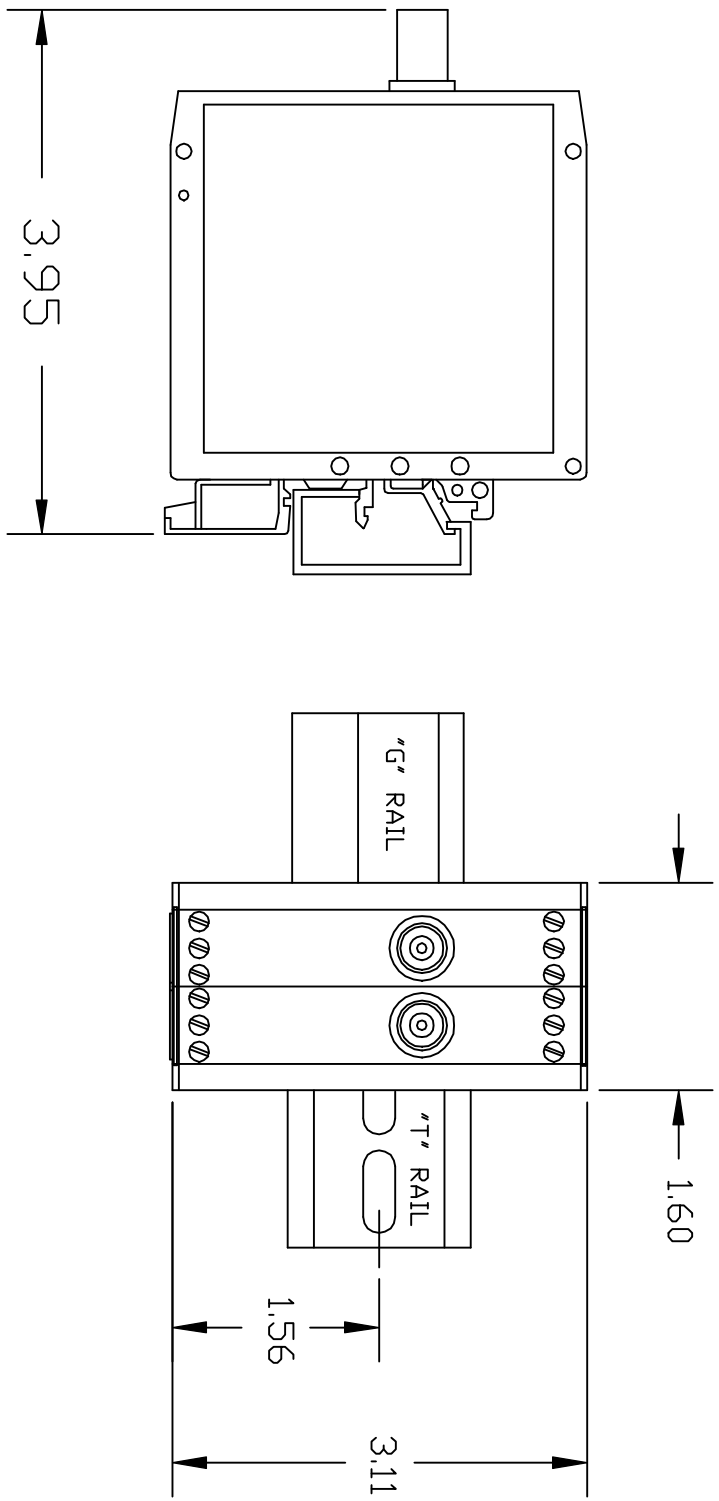

CMCP500 SERIES MONITOR MOUNTING AND OUTLINE		SIZE	FORM NO.	DWG NO.	REV
SCALE NONE					
SHEET 1 OF 1					

REVISIONS				
ZONE	REV	DESCRIPTION	DATE	APPROVED

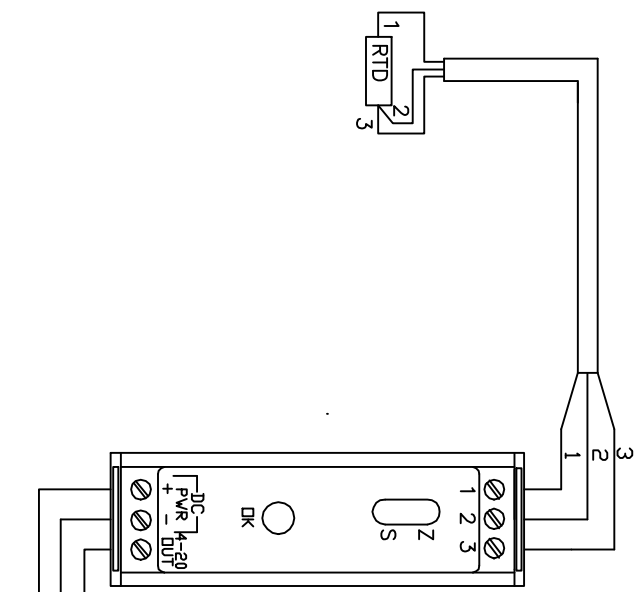

PLC/DCS channel input
 System Common
 +24 Vdc Power
 System Common (Shield)

CMCP560 CONNECTION		TRANSducer/POWER/OUTPUT	
SIZE	FORM NO.	DWG NO.	REV
SCALE	NONE	SHEET 1 OF 1	

4

3

2

1

REVISIONS				
ZONE	REV	DESCRIPTION	DATE	APPROVED

TOP PLUGABLE TERMINAL (for external meter connections)

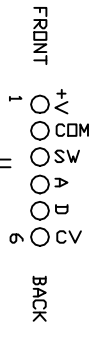

- +V - AUX. POWER OUTPUT (+20VDC at 20 mA max.)
- 0 - AUX. COMMON
- 2 - SWITCHED (front panel rotary switch) OUTPUT (0-5VDC)
- A - ALERT SET-POINT (0-5VDC)
- D - DANGER SET-POINT (0-5VDC)
- 0 - CURRENT VALUE (0-5VDC)

Alarm reset ('RST'), and trip multiply ('TX') terminals. External contact closure to the adjacent 'COM' terminal, or to instrument common activates

'DANGER' LED - Turns on when Danger setpoint is exceeded

BNC connector - Read switch selected values, using digital volt meter

Rotary switch - selects output to BNC connector above

Potentiometers for adjusting 'ALERT' and 'DANGER' setpoints. (Based on 0 to 5Vdc proportional to zero to full scale range of unit)

'ALERT' LED - Turns on when Danger setpoint is exceeded

'DK RELAY' - Normally energized. Contacts shown in 'DK' condition.

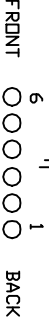

- FRONT 0 0 0 0 0 0 BACK
- NC $\frac{1}{2}$ ND NC $\frac{1}{2}$ ND
- ALERT DANGER
- ALERT & DANGER RELAYS - NORMALLY DE-ENERGIZED
- BOTTOM PLUGABLE TERMINAL

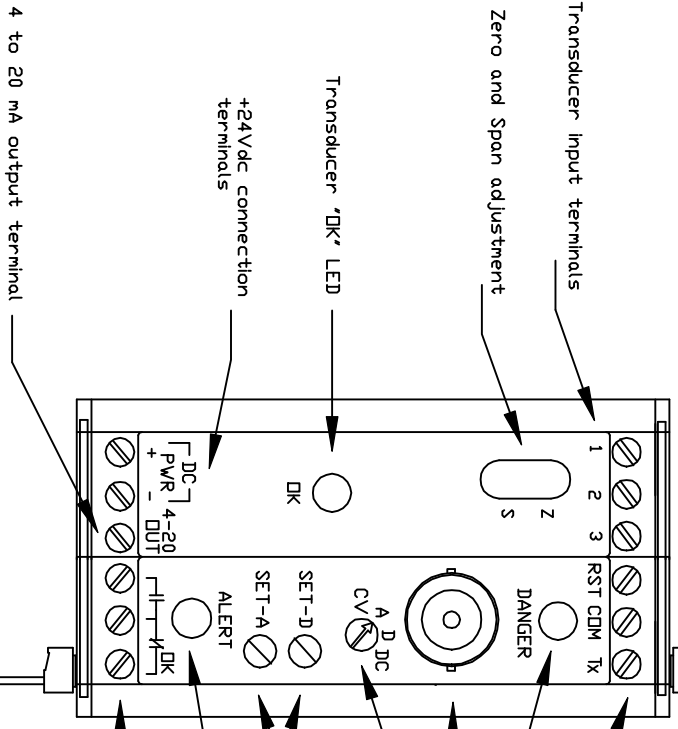

CMCP560/565 Connections

SIZE	PS&I NO.	DWG NO.	REV
SCALE	NONE	SHEET 1 OF 1	

4

3

2

1

REVISIONS				
ZONE	REV	DESCRIPTION	DATE	APPROVED

ALERT DELAY:
 E1 - .1 SEC
 E2 - 1 SEC
 E3 - 3 SEC
 E4 - 6 SEC
 E5 - 10 SEC

JUMPER INSTALLED - LATCHING
 JUMPER REMOVED - NON-LATCHING

ALERT LATCH
 DANGER LATCH
 TRIP MULTIPLY
 OPEN - 2X
 JUMP - 3X

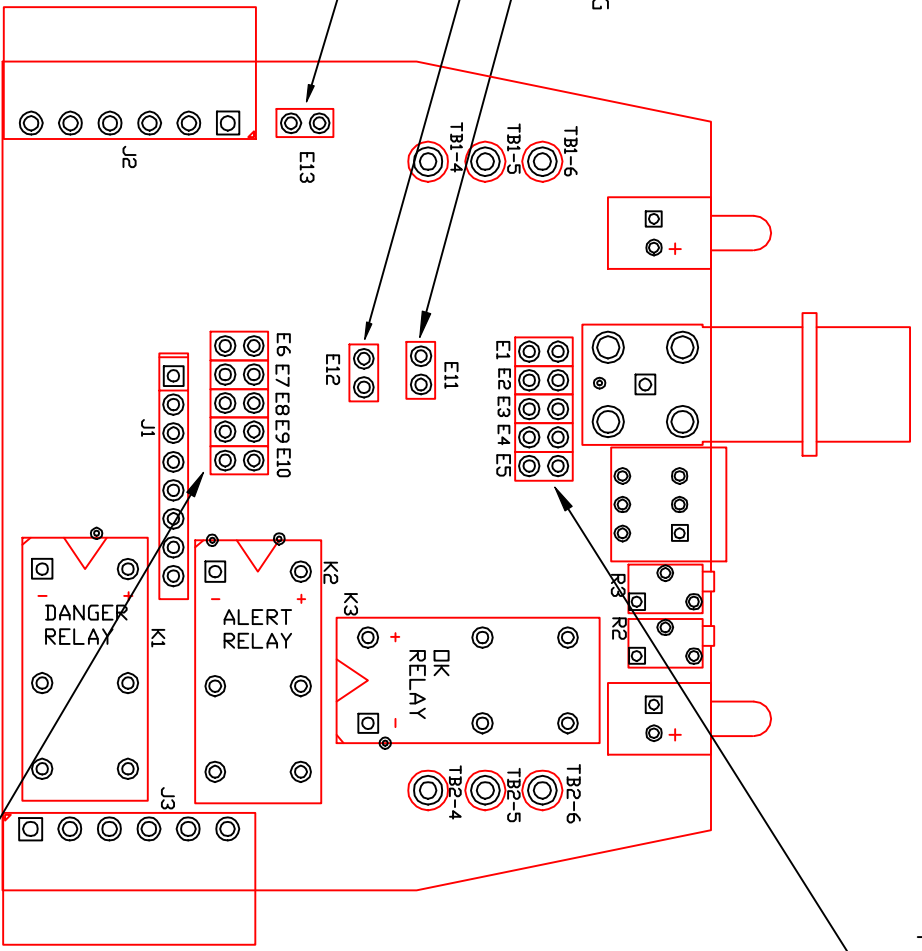

DANGER DELAY:
 E6 - .1 SEC
 E7 - 1 SEC
 E8 - 3 SEC
 E9 - 6 SEC
 E10 - 10 SEC

CMCP500 SERIES ALARM MODULE
 JUMPER LOCATIONS

SIZE	FORM NO.	DWG. NO.	REV.
C			
SCALE	NONIE	SHEET 1 OF 1	

A

B

C

D

4

3

2

1

A

B

C

D

REVISIONS				
ZONE	REV	DESCRIPTION	DATE	APPROVED

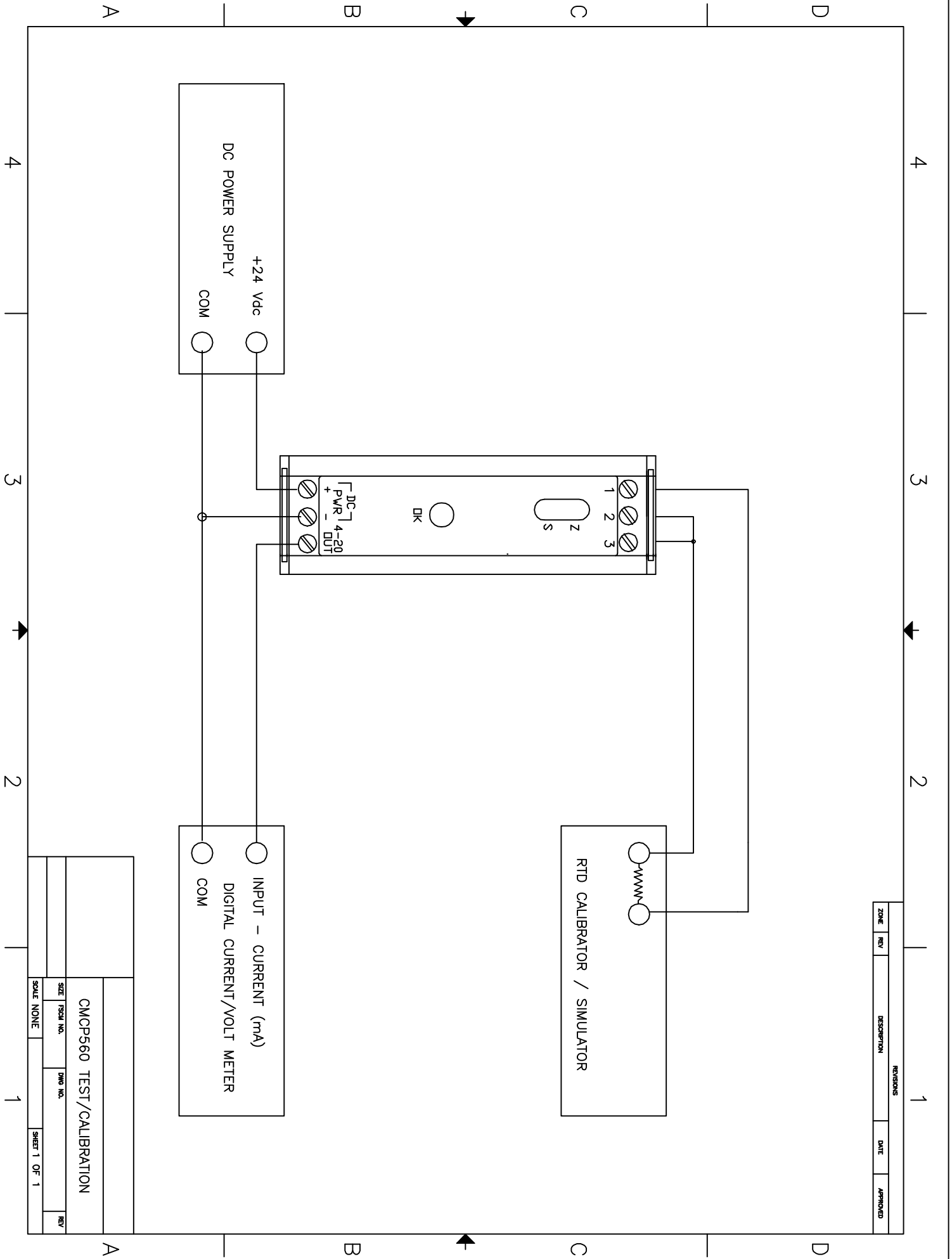

MCP560 TEST / CALIBRATION			
SIZE	PSHA NO.	DWG NO.	REV
SCALE	NONE		
SHEET 1 OF 1			